

FASTBLANK

BLANK PREDICTION SOFTWARE

A FORMING SUITE MODULE

Substantially improves formability and product quality

Reduces material costs and number of trials in the prove out stage

Accurately identifies material thinning and gathering conditions

Automatically generates a report for accurate quoting and estimating

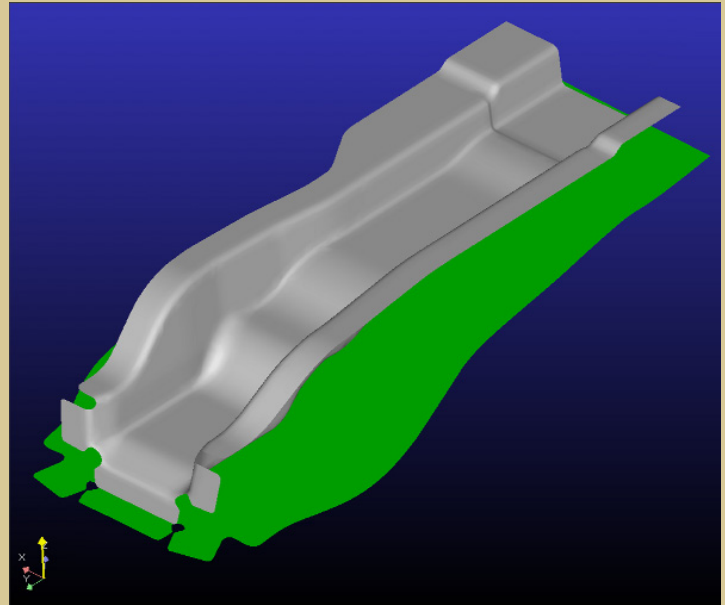

Fast and Accurate Blank Shape Development

FASTBLANK CALCULATES INITIAL BLANK SHAPES FOR DIE DESIGN AND COST ESTIMATING IN MINUTES

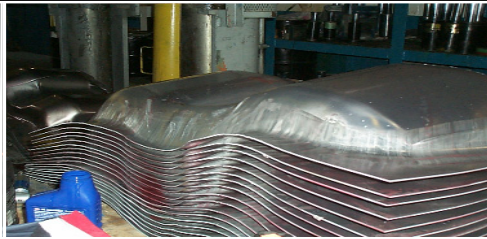

FASTBLANK

FASTBLANK provides users with a fast and accurate method for developing optimal blank shapes. It accounts for material stretch and deformation and is specifically designed for estimators, engineers, account managers, and tool and die designers.

FEATURES

- Simple and logical user interface - Designed for immediate productivity through a familiar Microsoft Windows environment and excellent on-line help
- Materials database - Built in materials database provides access to common materials for immediate analysis. Materials can be added, deleted, or modified in the database
- Geometry tools - Extensive set of easy to use tools for modifying and repairing imported surfaces
- Automatic or manual orientation of the part into the press direction. Displays undercut elements
- Fast solver - Most parts can be solved in 30 seconds to 5 minutes
- Exporting - The blank can be exported in IGES or DXF format for use in any CAD system
- Reports - HTML reports summarizing the on screen results can be printed and saved
- Plotting - Plot a full scale version of the blank

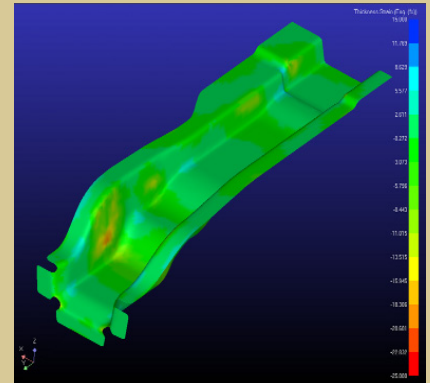

Easy user interface

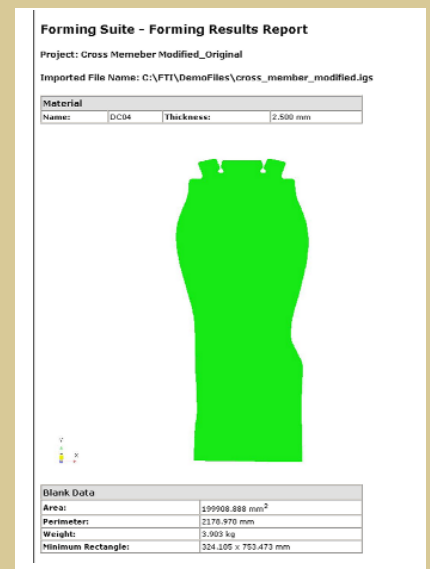

HTML report

ABOUT FORMING TECHNOLOGIES Forming Technologies Incorporated (FTI) is the world's leading developer of computer aided engineering software for design and simulation of sheet metal forming. FTI has developed a suite of products to analyze product formability, die design, and process feasibility. For the past 16 years, FTI has provided the automotive OEM, Tier 1, Tier 2, Tier 3, aerospace, and appliance industries with innovative software and training solutions designed to reduce development time and material costs. These solutions have resulted in millions of dollars of savings for our customers. FTI and its global network of partners provide sales and technical support to customers in more than 30 countries.



6-1075 North Service Road West,
Oakville, ON Canada L6M 2G2
Tel: 905-827-2997 Ext. 215
Fax: 905-827-3166

Please visit our website
at www.forming.com for
a FREE TRIAL COPY of

FASTBLANK